



**大緯電子**  
Darwei Electronic Co. LTD

# 4 Series Gas Detector Module

Model: ECM-01-U

## General Description

The gas sensors module is developed using a unique technology platform enabling sensor miniaturization, low-power consumption and ultra-fast response times for a wide range of applications.

The air quality we experience indoors and workplace are very important because we spend most of our time at home, at work, in school or in vehicles. However, offensive odors, smoke and other gases can have more impact on human comfort, productivity and health within a building.

The ECM-01-U is a low-power digital gas sensor solution, which integrates a gas sensor solution for detecting low levels of gases typically found indoors or workplace, with a microcontroller unit (MCU) and an Analog-to-Digital converter to monitor the local environment and provide a standard digital interface.



## Features

- Managing the sensor drive modes and measurements while detecting environmental gas
- Provides indication of IAQ and Industrial levels without a host intervention
- Simplifies development for faster time to market
- Extended battery life in portable applications
- Small form-factor designs
- Saves up to 60% in PCB footprint
- Designed for high volume and reliability (>2 year lifetime)

## Benefits

- Integrated MCU
- On-board processing
- Standard digital interface
- Optimized low-power modes
- Standard gas calibration has been completed
- Low component count
- Proven technology platform



# 大緯電子

Darwei Electronic Co. LTD

## Specification

Operating voltage range	3.7 to 24 VDC
Operating temperature range	-5 to 50 °C
Operating humidity range	10 to 95 %RH (no coagulation)
Preheating time	<=5 MIN
Sensor type	Electrochemical & Catalytic combustion
Sampling way	Diffusion
Equipment service life	Two years (in the air)

Note: Warranty does not include sensor.

The following different gas type sensors can be used.

Sensor type	Gas type	Range	Resolution
Electrochemical	O <sub>2</sub>	0 to 30 %	0.01%
	CO	0 to 1000 ppm	0.1ppm
	VOCs	0 to 1000 ppm	0.01ppm
	SO <sub>2</sub>	0 to 20 ppm	0.1ppm
	NO	0 to 250 ppm	0.5 ppm
	NO <sub>2</sub>	0 to 20 ppm	0.1ppm
	O <sub>3</sub>	0 to 10 ppm	0.02ppm
	C <sub>2</sub> H <sub>3</sub> CL	0 to 100 ppm	1ppm
	CL <sub>2</sub>	0 to 200 ppm	0.1ppm
	H <sub>2</sub> S	0 to 100 ppm	0.1ppm
	HCL	0 to 50 ppm	1ppm
	HCN	0 to 50 ppm	1ppm
	NH <sub>3</sub>	0 to 1000 ppm	0.5 ppm
	PH	0 to 20 ppm	0.1ppm
	CH <sub>3</sub> SH	0 to 10 ppm	0.1ppm
ETO	0 to 500 ppm	10ppm	
Catalytic combustion	CH <sub>4</sub>	0 to 100% LEL	1 % LEL

(Note: If you want to change the sensor, please contact customer service.)



大緯電子

Darwei Electronic Co. LTD

## Block diagram

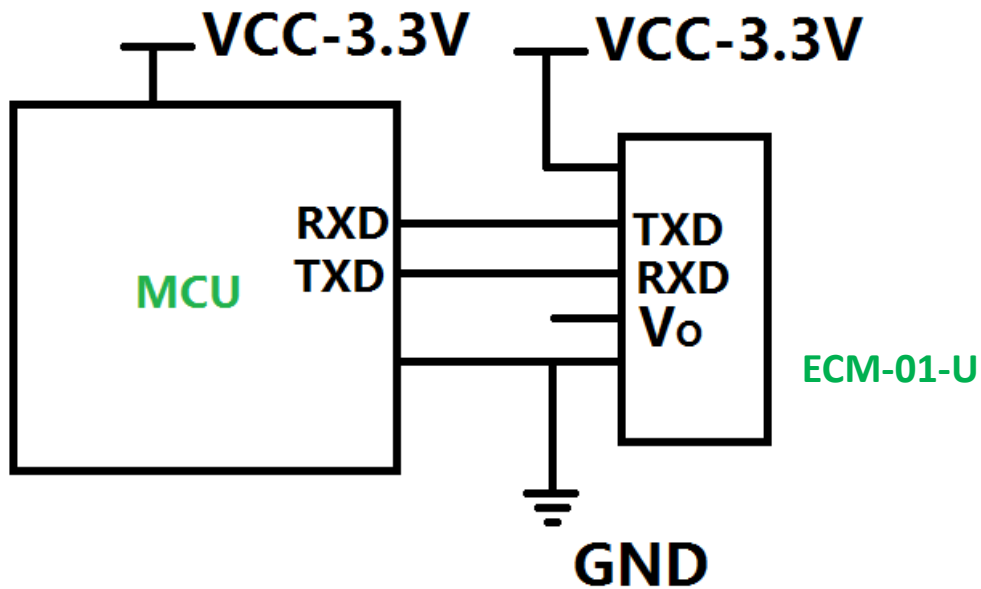

## Notes:

1. The electrochemical module is TTL level, please select the MCU for TTL level.
2. Other voltage system, please design level convert circuit.

## Package outline



## Pin assignment

Pin NO.	Name	Description
1	GND	Connect to ground
2	VCC	Supply voltage
3	Vo	Analog voltage output (preset)
4	RXD	UART_RXD pin is used for read data.
5	TXD	UART_TXD pin is used for transmit data.